

2-Person Portable Infrared Sauna

One of our most popular models, the S-820 is perfect for one or two people. With its footprint of only 13.3 square feet, it can easily be incorporated into an in-home workout area, master bath, or other area with room to spare. Share the infrared heat and benefits with a friend, or sauna solo!



A. BLUETOOTH SOUND SYSTEM

Integral state-of-the-art sound with heat-resistant speakers. Just pair with your Bluetooth®-ready device.

B. ELEGANT LED LIGHTING

Great for relaxing and mood creation, with 6 color options.

C. FULL-SIZED CALF EMITTERS

For maximum lower extremity exposure to healthy far-infrared heat energy.

D. WALL-TO-WALL HEAT COVERAGE

No hot and cold spots here! Total immersion in the highest output of Low EMR & Low EF infrared heat energy in the industry.

E. ALL-GLASS FRONT WALL

Non-claustrophobic feel with a clean, contemporary look.

F. CANADIAN HEMLOCK INSIDE & OUT

Responsibly harvested sauna wood sealed with bio-friendly furniture grade finish.

G. IL2 CONTROL SYSTEM

The proprietary InfraLogic2 control is feature-rich and easy-to-use to set and schedule your sauna sessions. Extend control to your phone and operate your sauna from anywhere with the mobile app.

H. COMBINATION DOOR HANDLE

It's a door handle that doubles as a towel bar.

I. IN-BENCH FAR-INFRARED EMITTER

The only infrared sauna in the industry with this feature!

J. MATTE BLACK METALLIC FLOOR EMITTER

For complete head-to-toe comfort, rest your feet on the CarbonFlex™ far-infrared floor emitters.

SPECIFICATIONS



Seats up to 2



Inside only



Low EMR & EF



WiFi



Bluetooth



15-amp 120v. Standard Outlet

TECHNICAL

Dimensions: 47^{3/4}" W x 40" D x 76^{1/2}" H

Weight: ~345 lbs.

Electrical: 15-amp 120 V standard outlet

CONSTRUCTION

Clear Canadian Hemlock construction

CarbonFlex™ Low EMR/Low EF heating system

"Pin-and-Hook" wall locking system

3" side and 5" overhead clearance required for installation

WARRANTY

IR Emitters: 5 years

Wood Cabinet: 5 years

Controls: 5 years



ETL Listed for Safety

Peace-of-mind for you and your loved ones.



EXTERIOR FRONT WALL

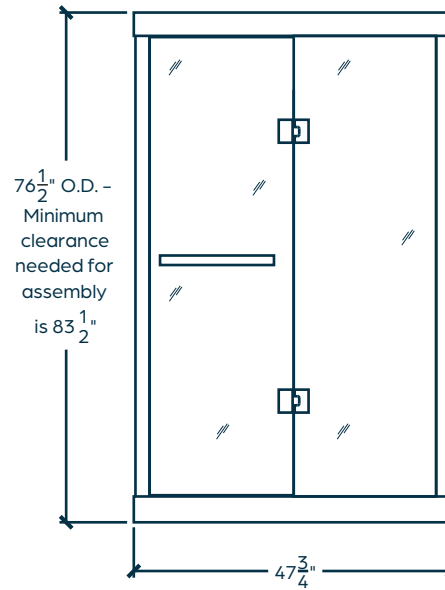

INTERIOR LEFT WALL

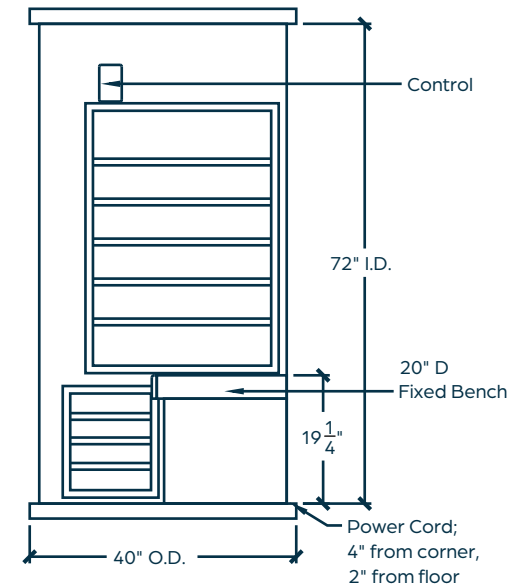

TOP DOWN VIEW

(w/ Interior Measurements)

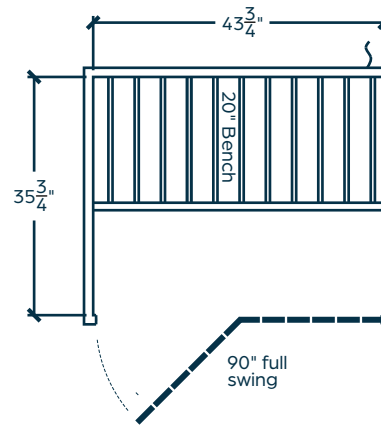

Notes:

Dealer Contact Information:

S-Series S-820

PORTABLE SAUNA

Version: V4
 Part Number: 9804-4420
 Heater Model: CarbonFlex IR
 Control Type: IL2 w/Wi-Fi
 Voltage: 120

Phase: 1
 Amps: 15
 Watts: 1580
 Ext. Wood: Canadian Hemlock
 Int. Wood: Canadian Hemlock

Cord Length: 6'
 Door Type: All-Glass, Clear
 Door Dimensions: 21⁵/₈" x 68³/₄"
 SQ. Footage: 10.9
 CU. Footage: 65.4

Lighting Type: Under Bench/Valance
 Largest Panel Size: 47³/₄" x 76¹/₂"
 Drawing Rev. Date: 4-27-2022
 Shipping Weight (Palletized): ~420 lbs.

*Finnleo / Sauna360 reserves the right to make changes to these measurements from time to time without notice.